

University  
of Lille  
(France)



[www.emrwebsite.org](http://www.emrwebsite.org)

**“Modelling and control using  
ENERGETIC MACROSCOPIC REPRESENTATION”**  
Application to hybrid electric vehicles and others

**17<sup>th</sup> – 19<sup>th</sup> June 2019**

(The 20<sup>th</sup> of June is only mandatory for students who need academic credits)

Université de Lille, France

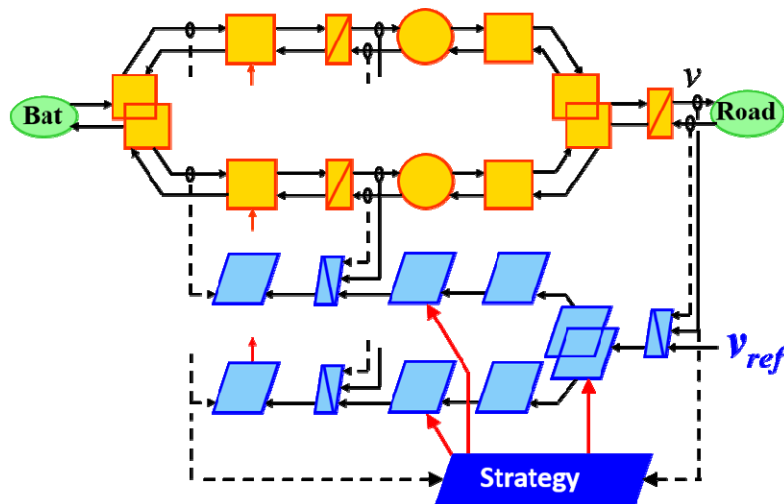

EMR of an Electric Vehicle



EMR'18, June 2018, Hanoi, Vietnam

SCIENTIFIC SUPPORTS



## OBJECTIVE

This workshop is focused on the **Energetic Macroscopic Representation (EMR)** methodology for modelling and control of complex electromechanical systems.

This Summer School is aimed at Master and PhD students, Engineers and scientists, from both academia and industry, who have to **model and control new multi-physical systems** such as industrial multi-drive systems, traction and propulsion systems, hybrid electric vehicles, or renewable energy generation systems.

EMR is a graphical formalism that was introduced in 2000 to describe complex electromechanical systems. EMR has since been extended to complex multi-physical systems (combining thermal science, electrochemistry, fluid mechanics ...). EMR is based on the action-reaction principle to organize the interconnection of models of sub-systems according to the physical causality (i.e. integral causality). This description highlights energetic properties of the system (energy accumulation, conversion and distribution). Moreover, an **inversion-based control** can be systematically deduced from EMR using specific inversion rules.

Compared with other graphical description, such as Bond Graphs or Causal Ordering Graphs (COG), EMR has a more global energetic view and contributes to system's control design. It differs from structural description tools such as Physic Modelling Language (PML) using Object-Oriented Modelling Language, which makes its libraries to be coupled in the same way as physical units. EMR is focused on the system function and not only on the system structure. EMR gives insights into the real energy operation of systems and allows a deep understanding of its potentialities from a dynamic point of view.

In short, the distinct features of EMR lie in its clarity of physical concepts, as well as their physical causality, and its functional description rather than a structural description. It hence contributes significantly to the design of control and energy management of systems.

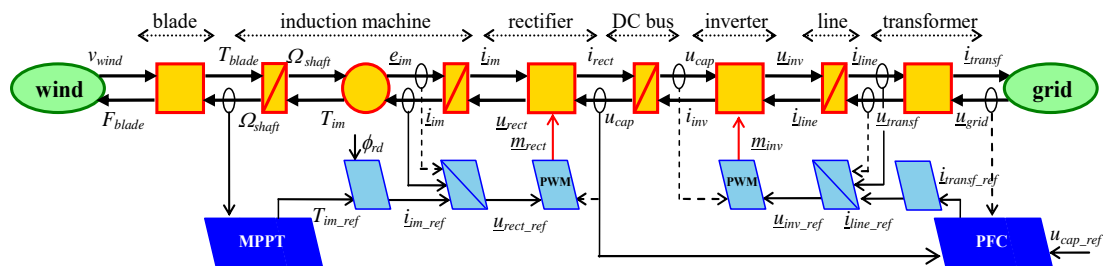

*Energetic Macroscopic Representation of a Wind Energy Conversion System*

## PREVIOUS EMR SUMMER SCHOOL



*EMR'16, June 2017, Montreal, Canada*



*EMR'17, June 2017, Lille, France*

*EMR'06 - Lille (France),*

*EMR'08 - Harbin (China),*

*EMR'09 - Trois-Rivières (Canada),*

*EMR'11 - Lausanne (Switzerland),*

*EMR'12 - Madrid (Spain)*

*EMR'13 - Lille (France),*

*EMR'14 - Coimbra (Portugal),*

*EMR'15 - Lille (France),*

*EMR'16 - Montreal (Canada)*

*EMR'17 - Lille (France)*

*EMR'18 - Hanoi (Vietnam)*

## SIMULATION TRAINING SESSION

The aim of this Summer School is to **give a first-hand experience in practice of using EMR and inversion-based control**. Three afternoons will be dedicated to simulation training sessions using MATLAB®-Simulink®. Attendees will simulate a complete system and its control using EMR methodology. They will choose to study an electric vehicle, a photovoltaic system or a wind energy conversion system. An EMR library will be provided to all attendees.

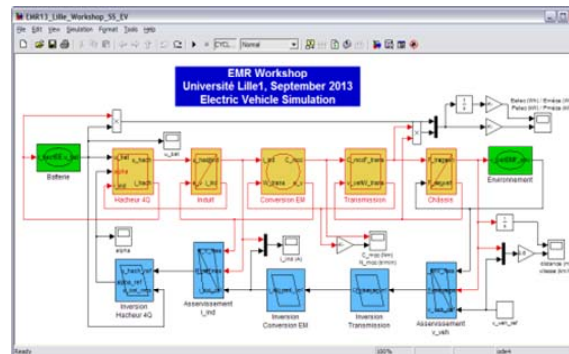

*MATLAB®-Simulink® model of an Electric Vehicle (orange)  
and its control (blue) derived from EMR*

## PROVISIONAL SCHEDULE

### — Monday 17<sup>th</sup> of June 2019 —

8:30 – 13:00: Lectures on fundamentals on EMR and inversion-based control, basic examples  
14:30 – 18:00: Simulation training session (part I), modelling of the considered system

### — Tuesday 18<sup>th</sup> of June 2019 —

9:00 – 13:00: Lectures on applications to complex systems (part I)  
(Hybrid Electric Vehicles, Automatic subway traction systems, Fuel Cell systems...)  
14:30 – 18:00: Simulation training session (part II), control of the considered system

### — Wednesday 19<sup>h</sup> of June 2019 —

9:00 – 13:00: Lectures on applications to complex systems (part II)  
(wind energy conversion systems, PV systems, Piezoelectric actuators, multiphase drives...)  
14:30 – 18:00: Simulation training session (part III), control of an electric drive

### — Thursday 20<sup>nd</sup> of June 2019 (for academic credit validation only)—

9am – 1pm: Preparation of case applications (International PhD students)  
2pm – 6pm: Presentation of case applications (International PhD students)

The full program will be available at <http://www.emrwebsite.org/> (see for example the program of last year EMR summer school on the website)

## LANGUAGE

Lectures will be presented in English.  
The training sessions will be taught in English and French.

## WORKSHOP ORGANIZATION

This workshop is organized by the L2EP of University of Lille (France).

### *General chair*

Dr. Ronan GERMAN (University of Lille, L2EP, MEGEVH, France)

### *Co-chair*

Prof. Alain BOUSCAYROL (University of Lille, L2EP, MEGEVH, France)

### *Scientific committee*

Dr. Philippe BARRADE (University of Applied Sciences of Sion, Switzerland)

Prof. Loïc BOULON (Université du Québec à Trois-Rivières, GRÉI, Canada)

Dr. Lucia GAUCHIA (MichiganTech University, USA)

Prof. Daniel HISSEL (University of Franche Comté, FEMTO-ST, MEGEVH, France)

Prof. Betty LEMAIRE-SEMAIL (University of Lille, L2EP, France)

Dr. Daniel MONTESINOS (Universitat Politècnica de Catalunya, Spain)

Prof. Paulo PEREIRINHA (Polytechnic Institute of Coimbra, INESC Coimbra, Portugal)

Prof. Minh Cao TA (Hanoi University of Sciences and Technology, Vietnam)

Prof. João Pedro TROVÃO (Université de Sherbrooke, e-TESS Lab., Canada)

## REGISTRATION

Due to the simulation training session, the number of attendees is limited to 50. A registration form is required. The registration fees include coffee breaks, lunches, the workshop booklet and the access to the .pdf file and the EMR library. Registration will open at the beginning of 2019.

	<b>Before May 31<sup>st</sup></b>	<b>After May 31<sup>st</sup></b>
<b>Students</b>	<b>100 €</b>	<b>150 €</b>
<b>Academic</b>	<b>210 €</b>	<b>420 €</b>
<b>Industrial</b>	<b>320 €</b>	<b>640 €</b>

An attendance certification will be provided for French students (Doctoral Schools) and students from other countries (3 equivalent ECTS in Europe for example). For other education systems an attendance certificate will provide the detail of courses with lesson and practical works hours.

## INFORMATION

Contact: [ronan.german@univ-lille.fr](mailto:ronan.german@univ-lille.fr)

The summer school takes place in **LILLIAD**,  
avenue Henri Poincaré, cité scientifique, **59655 Villeneuve d'Ascq** France.  
**Subway station " 4 cantons" (Line 1)**

More information: <http://www.emrwebsite.org/>